

Temporary Traffic Signs & Traffic Management

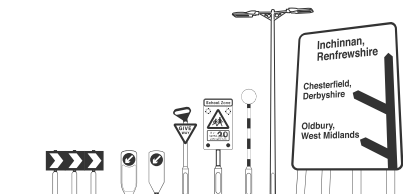

www.mallatite.co.uk

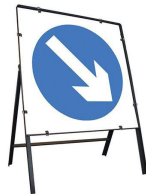

MADE IN BRITAIN

Steve Garrett

T. 07990 442 605

E. steve.garrett@mallatite.co.uk

W. www.mallatite.co.uk

Temporary Signs

1050mmx750mm



1050mmx450mm



600mmx450mm



750mm Triangle



860mmx360mm Supplementary



750mm Circle

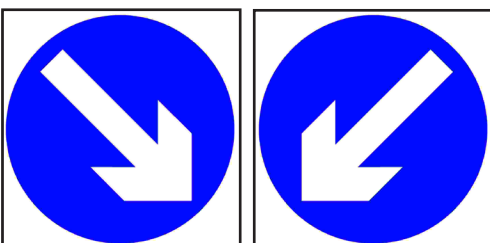

Other materials, sizes, fixing methods as well as bespoke designs are available upon request.

Temporary Sign Frames

Robust traffic sign frames made using 25mm x 3m thick steel angle painted grey.

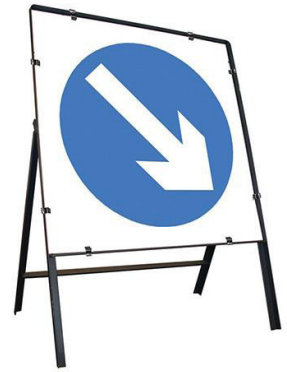

Frame Sizes

600 x 450 mm
1050 x 450 mm
1050 x 750 mm
750mm square
750mm triangle
750mm triangle plus supplementary plate

Other sizes available upon request:
groupsales@mallatite.co.uk

QUICK FIT FRAME SYSTEM

There are many variations of frame that we produce and can tailor to your specific needs. We can add your company name plate on the frame should you require it and we also offer a powder coated finish in any colour on the ral chart.

Other sizes are available contact groupsales@mallatite.co.uk

900 QUICK FIT FRAME

FRAMES ARE OF WELDED CONSTRUCTION
FROM 25 x 25 x 1.5 mm MS. SQUARE HOLLOW SECTION.
FRAMES ARE DIP FAINTED GREY PRIMER
OR ALUMINIZED FINISH.
GROSS WEIGHT OF 900 FRAME = 18 Kgs. APPROX.

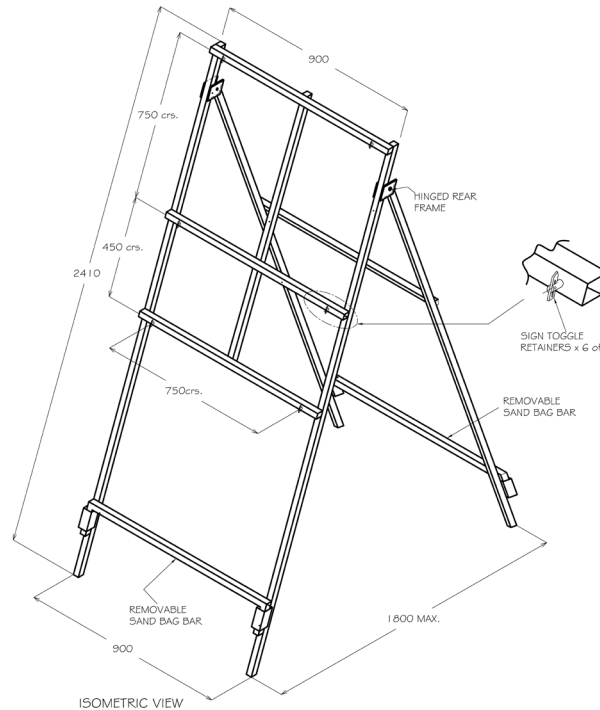

1200 QUICK FIT FRAME

FRAMES ARE OF WELDED CONSTRUCTION
FROM 25 x 25 x 1.5 mm MS. SQUARE HOLLOW SECTION.
FRAMES ARE DIP FAINTED GREY PRIMER OR ALUMINIZED FINISH.
GROSS WEIGHT OF 1200 FRAME = 23 Kgs. APPROX.

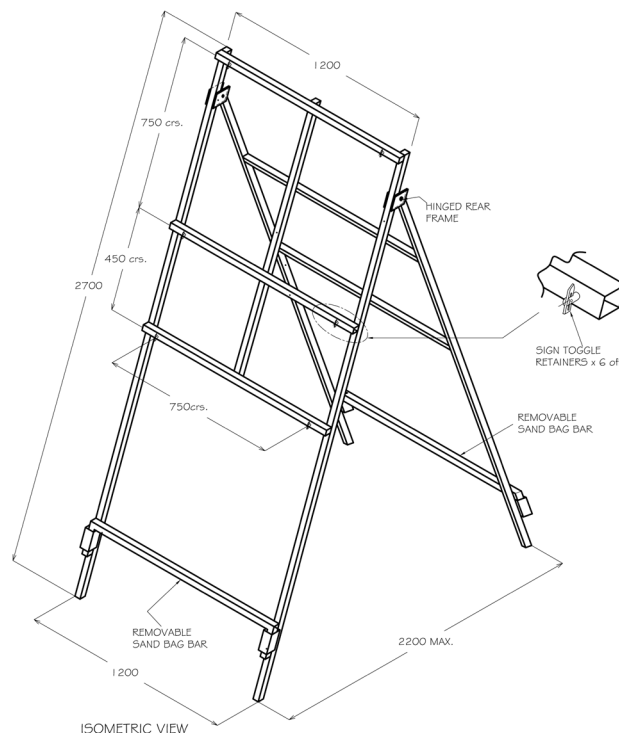

ENDURASIGN™ XTRA - TEMPORARY SIGNS

The EnduraSign Xtra is an incredibly durable, long-life, temporary and patented plastic sign. It is available with round, rectangular and triangular faces.

- Easily installed, transported and stored
- Withstands tough site conditions such as being driven over or dropped from height
- Clearly signposts critical information with a simple installation process
- Creates clear signage and informative executions in all weather
- Use with EnduraSign™ Ballast for Cat A wind resistance
- Eliminate sandbag debris with the stackable EnduraSign™ Ballast



- Available with EnduraSign™ Xtra Heavy frame for built in wind-resistance
- Clearly label equipment with corporate nameplate insert
- Deliver safe and useful information for multiple scenarios and purposes (pedestrian, road traffic, site safety, event coordination/ navigation)
- A closed loop recycling products: parts made of recycled PVC



ENDURASIGN™ XTRA 750MM TRIANGLE ENDURASIGN™ XTRA 1050MM RECTANGLE

Product No.0480
Width 911mm
Length 734mm
Height 1049mm
Weight 7.25kg
Quantity / Pallet 50
Colour Black

Product No.0478
Width 1095mm
Length 734mm
Height 1045mm
Weight 9.8kg
Quantity / Pallet 50
Colour Black



ENDURASIGN™ XTRA 750MM CIRCLE

Product No. 0481
Width 797mm
Length 734mm
Height 1054mm
Weight 7.25kg
Quantity / Pallet 50
Colour Black

ENDURASIGN™ XTRA 600MM RECTANGLE

Product No. 0482
Width 797mm
Length 734mm
Height 871mm
Weight 7kg
Quantity / Pallet 50
Colour Black



HIGHWAYMAN CONE SYSTEM

ROAD CONES

This 2 part road cone provides safety to worksites, and is ideal for use in heavy traffic, motorway contraflow systems (750mm), lane delineation and parking control at events. The easy-to-use Cone Rope is used with road cones to create a hi-vis temporary perimeter.

Usage Benefits

- Can be easily installed, transported and stored
- Can clearly and easily demarcate areas of road, walkways and work sites
- Create temporary separation of high traffic and restricted zones
- 2 part cone with durable recycled PVC base, outlasts 1 part cone alternatives
- Create clearly defined thoroughfares to safely direct traffic and vehicles
- Can effectively cover small and large areas with a quick and effortless installation
- A closed loop recycling product: made using recycled PVC



HIGHWAYMAN CONE 50CM

Product No. O9102
Width 285mm
Length 285mm
Height 500mm
Weight 2.5kg
Quantity / Pallet 400
Colour Orange

HIGHWAYMAN CONE 75CM

Product No. O9101
Width 430mm
Length 430mm
Height 750mm
Weight 4.6kg
Quantity / Pallet 150
Colour Orange

HIGHWAYMAN CONE 1M

Product No. O9100
Width 540mm
Length 540mm
Height 1000mm
Weight 7kg
Quantity / Pallet 100
Colour Orange

CONE ROPE

Product No. O9940
Width 10mm
Length 18000mm
Height 10mm
Weight 1kg
Quantity / Pallet 100
Colour Orange

AVALON® BARRIER



PEDESTRIAN BARRIER

The Avalon is our most versatile and popular safety barrier. It is compliant with street works regulations and suitable for a wide range of indoor and outdoor pedestrian applications. Common uses include construction, excavation, street works, events and utilities sites.

Usage Benefits

- Adaptable to the work site's requirements with 3 feet options: ClearPath Extra which is 100% anti-trip, ClearPath or Standard
- Can be easily transported and stored
- Clearly defined access in high traffic area
- Ensure mandated physical distance measures
- Keep a secure semi-permanent perimeter with our ballasting options, offering wind resistance up to Cat A
- Patented tamper-proof locking system to protect site staff and pedestrians against risk factors
- Maintain quality and performance with spare parts, if necessary
- Enquire about minimum order quantities for customisations



AVALON 500MM

Product No.O646
Width 40mm
Length 655mm
Height 1000mm
Weight 1.8kg
Quantity / Pallet 100
Colour Orange



AVALON 1M

Product No.O634
Width 40mm
Length 1000mm
Height 1000mm
Weight 8.5kg
Quantity / Pallet 50
Colour Orange



AVALON 2M

Product No.O635
Width 40mm
Length 2005mm
Height 1000mm
Weight 11kg
Quantity / Pallet 50
Colour Orange



ENDURARAMP™

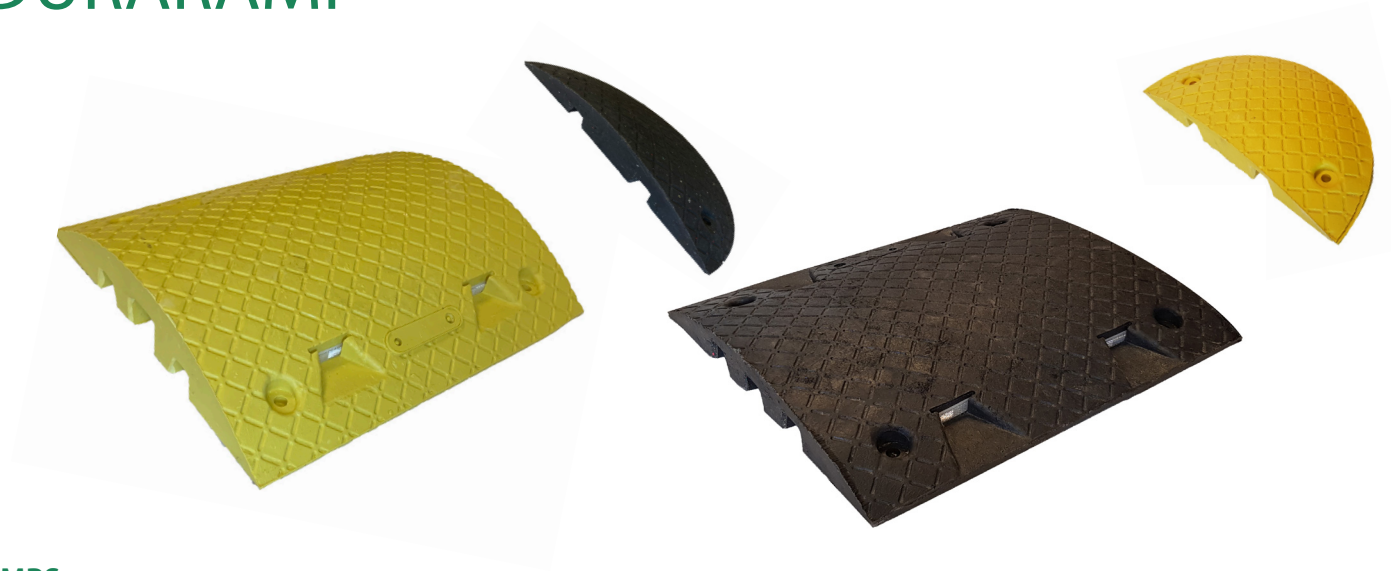

SPEED BUMPS

The EnduraRamp slows down traffic at your worksite, school or wherever traffic calming is required. This speed bump is durable and easy to install.

Usage Benefits

- Lightweight and durable solution for easy installation
- Can be easily installed, transported and stored
- Manage speed of traffic effectively across site and pedestrian areas
- Create highly-visible traffic management solutions with in built reflective
- Support road traffic, vehicles and cargo up to 44 tonnes
- Thick plastic moulded coloured skin which provides long-lasting hi-vis colours
- Run cabling and piping of up to 22mm diameter within the ramp's recess
- Protect site staff and pedestrians against traffic and vehicles
- A closed loop recycling product:made of recycled PVC



ENDURARAMP™ 50MM END

Product No. O310/O377
 Width 420mm
 Length 210mm
 Height 50mm
 Weight 3.5kg
 Quantity / Pallet 120
 Colour Black/White

ENDURARAMP™ 75MM END

Product No. O323
 Width 420mm
 Length 210mm
 Height 75mm
 Weight 4.5kg
 Quantity / Pallet 100
 Colour Yellow/Black

ENDURARAMP™ 50MM INNER

Product No.O376
 Width 420mm
 Length 500mm
 Height 50mm
 Weight 9kg
 Quantity / Pallet 100
 Colour Yellow/White

ENDURARAMP™ 75MM INNER

Product No. O378/O321
 Width 420mm
 Length 500mm
 Height 75mm
 Weight 12kg
 Quantity / Pallet 100
 Colour Yellow/Black